

Foot Mounted Electric Wire Rope Hoist

Hoist model VATP2512TpE3N

Capacity - 5 tonne in FEM9.511 - 2m
 Lifting Height - 7.5m
 Lifting Speed - 4.8/1.2 m/min
 Voltage - 230,460, 575V-3ph-60Hz
 Rope Reeving - 4/1

Lifting Motor model KV2003P-24/6

Rated power - 1.1/4.6 kW
 Switches per hour - 240/120h-1

Net Weight - 390kg

Mechanical overload protection (OL)

Optional thermal overload protection (Tp)

Electric panel not shown

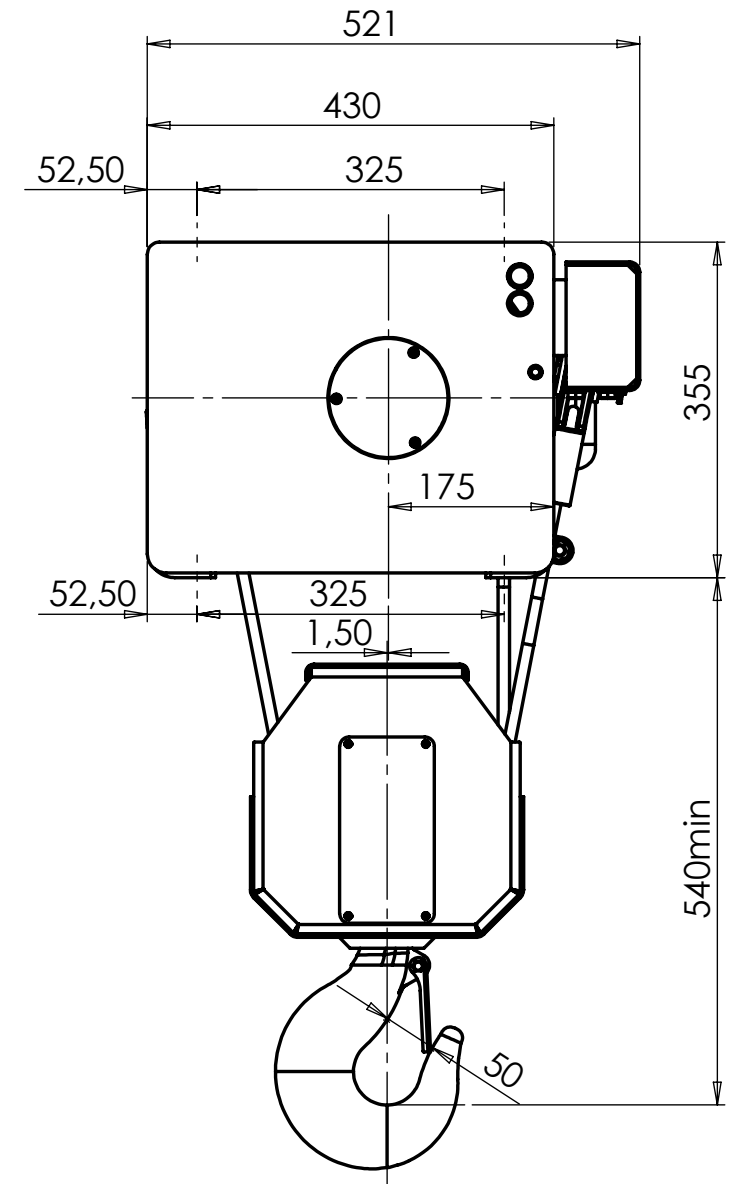
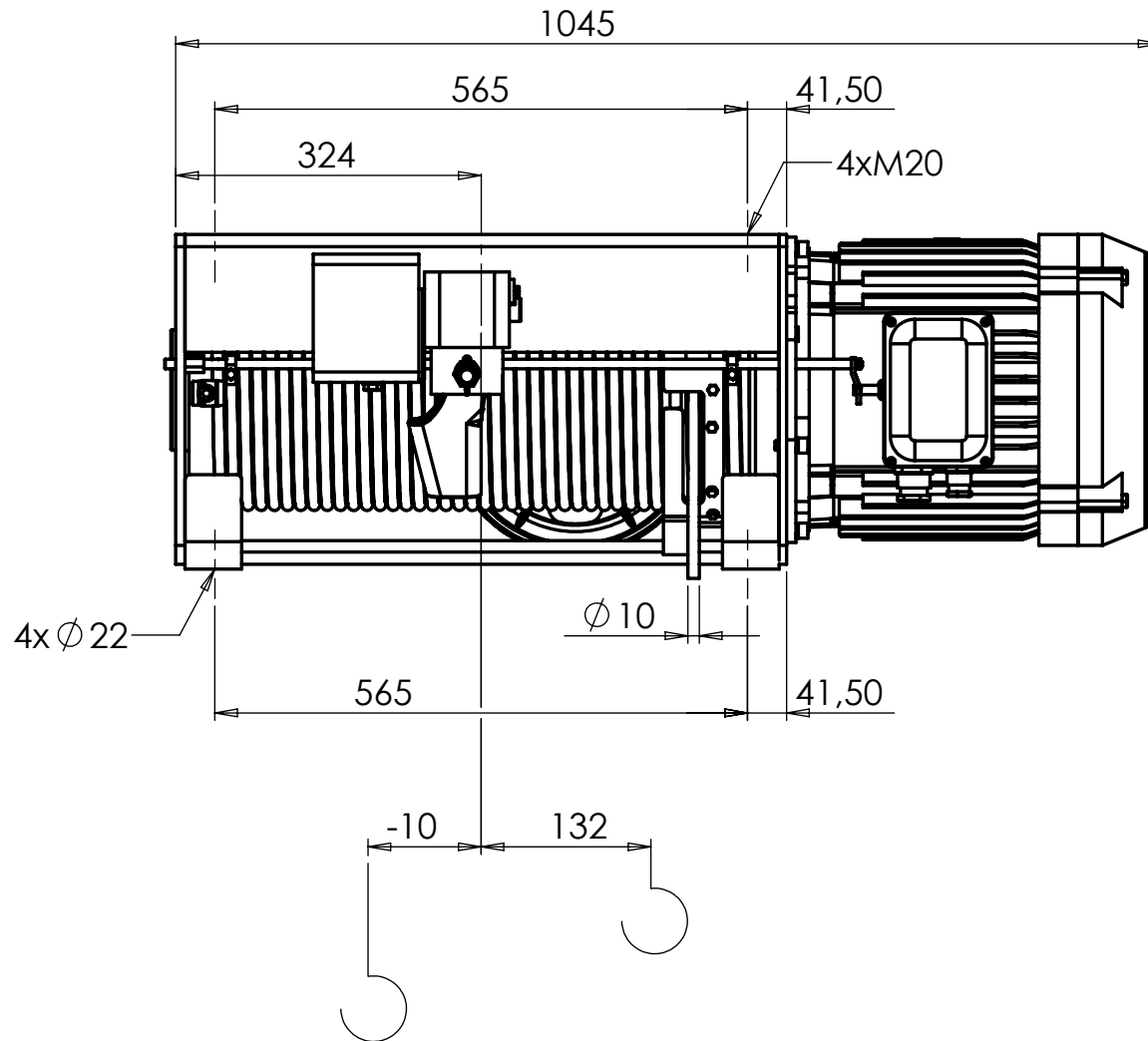

t 604 796 9221 e integrity@hydramachcrane.com
 f 604 796 9227 www.hydramachcrane.com

*Dimensions and specifications subject to change without notice.